

Order form 1/2

Above-ground safety automatic cover

Please fill in these documents and send them with your order.

Company:

Reference:



Rolltop Design



Rolltop2
 Rolltop3



Rolleasy electrical
 Rolleasy manual



Rollsun Design



Rollsun2

Tick the model required.

Pool dimensions: Length: m Width:m Vertical radius:cm

Type of pool: Fibreglass Steel/plastic panels Concrete Polyblocks

Pool finish: Liner Reinforced membrane Fibreglass Tiles

End stand colour: White Beige Grey

Slats: 69 mm: White Beige Blue Grey

Step unit: Straight Trapezoidal Roman Inside

Note: All cut slats for steps are "square cut" using end caps

Skimmers: On length AC On length BD On width AB On width CD

skimmer width:cm

Skimmers position: Flush with wall Proud bycm

Overflow system: On length AC On length BD On width AB On width CD

A drawing of the overflow channel is required.

Motor location: A B

Distance required between supports: (Pool width + 30 cm as standard - maximum + 60 cm)

Safety kits: Pushlock Quicklock

Specify the colour required: White Beige Blue Grey

White Straplocking kit White Lockit

Model: Insert mounted Surface mounted Hanging mounted

Not installed Already installed (specify the exact position on the drawing)

Type of anchor for the Straplocking Kit: Wooden copings Concrete coping stones

"Read this document carefully and keep it in a safe place for a later reference"

"This safety cover is designed to prevent access to the pool for children under 5 years old." The purpose of this cover does not replace the vigilance of the parents and/or the responsibility of adults which remains the essential factor for the protection of young children.

Attention: The cover cannot be relied on to offer any degree of safety for a deck level/overflow pool, or where there is a side step unit.

Delivery address

Name: _____

Address: _____

Postcode: _____ Country: _____

Telephone: _____ Fax: _____

Access: Truck Small lorry Other: _____

Date and Signature

Company Stamp

Please make sure you fill in all information requested in the 2 pages to avoid manufacturing delays.

Golden Coast Ltd | Fishleigh Road | Roundswell Commercial Park West | Barnstaple | Devon | EX31 3UA | T: 01271 378100 | F: 01271 371699



Above-ground safety automatic cover

Please fill in these documents and send them with your order.

Company: Reference:



Rolltop Design



Rolltop2
 Rolltop3



Rolleasy electrical
 Rolleasy manual



Rollsun Design



Rollsun2

IMPORTANT: indicate the exact location of:

- Skimmers:
- Locking kits (if already installed)

Diagonals:

A D = cm

B C = cm

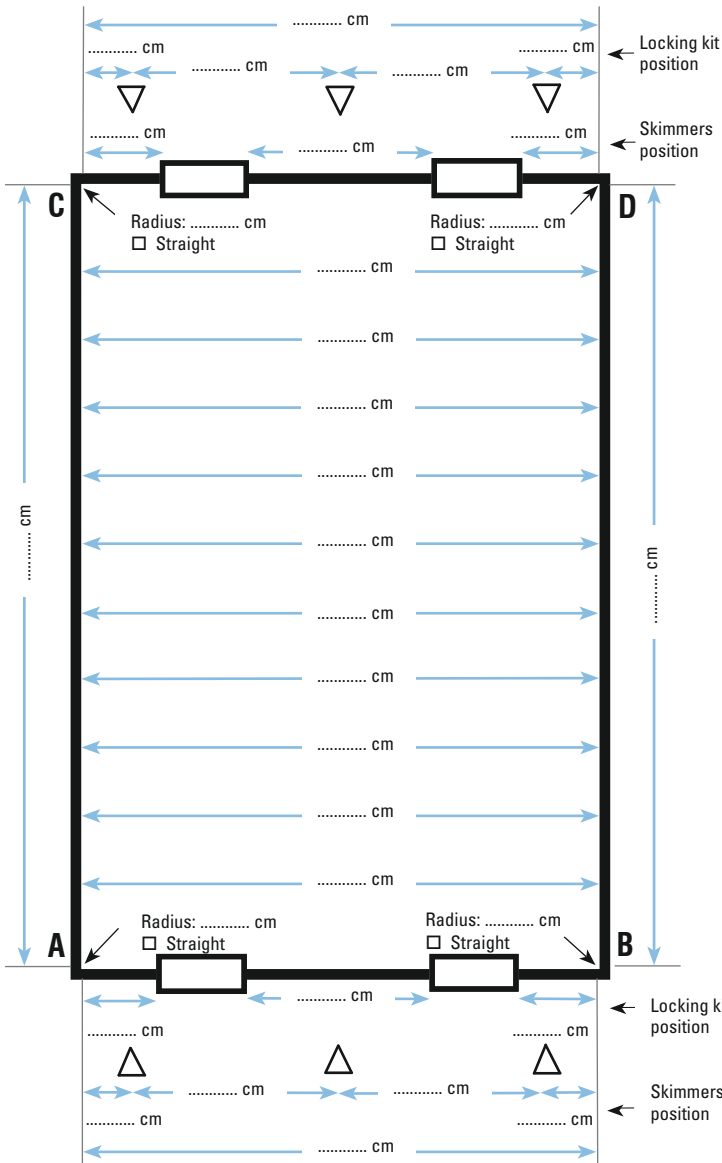

Important: the width of the pool must be taken every meter.

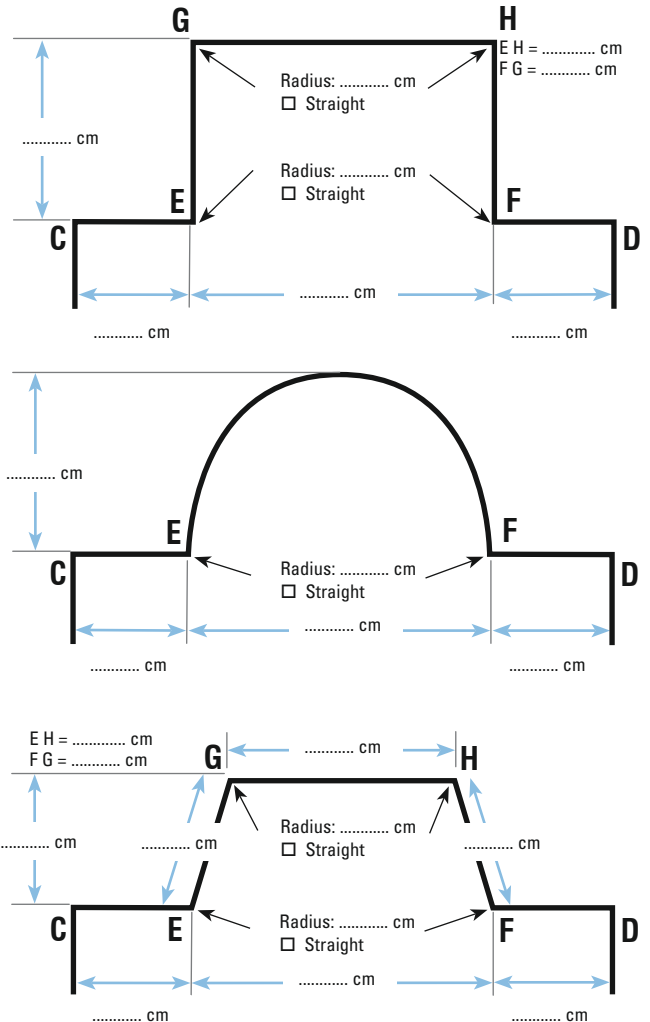
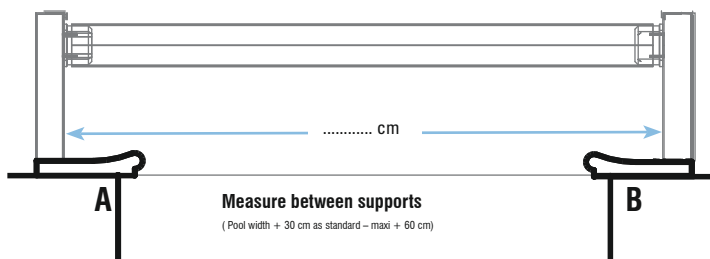

Additional Information

Date and Signature Company Stamp